

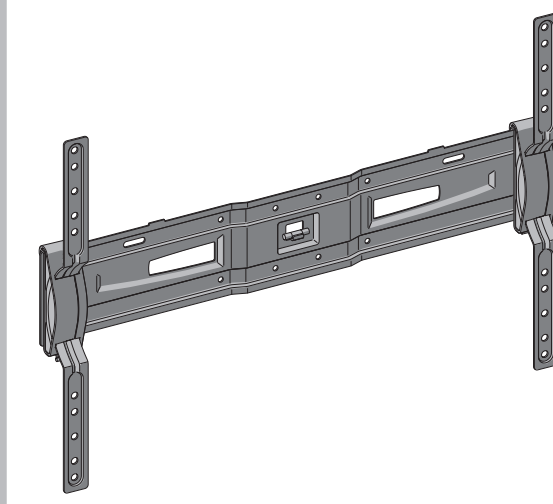

# FLATSTYLE FT600

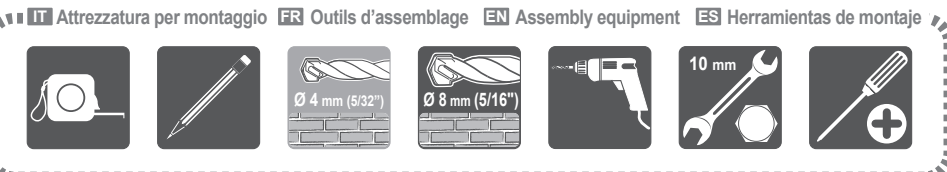

IT ISTRUZIONI DI MONTAGGIO  
FR INSTRUCTIONS DE MONTAGE  
EN MOUNTING INSTRUCTIONS  
DE MONTAGEANLEITUNG  
NL MONTAGEVOORSCHRIFT  
ES GUÍA DE MONTAJE  
PT INSTRUÇÕES DE MONTAGEM  
EL ΟΔΗΓΙΕΣ ΣΥΝΑΡΜΟΛΟΓΗΣΗΣ  
RU ИНСТРУКЦИИ ПО УСТАНОВКЕ  
PL INSTRUKCJA MONTAŻU  
CZ NÁVOD K MONTÁŽI  
RO INSTRUCȚIUNI DE MONTARE  
HU SZERELÉSI ÚTMUTATÓ  
SE MONTERINGSANVISNINGAR  
NO MONTERINGSINSTRUKSJONER  
FI ASENNUSOHJEET



IT Dati tecnici FR Caractéristiques techniques EN Technical data ES Datos técnicos

<b>FT600</b> 50" - 86" 127 - 218 cm	<b>FT600</b> 1,9 kg 4.2 lbs	<b>IT</b> Muro in mattoni pieni o cemento armato <b>FR</b> Mur en briques pleines ou en béton armé <b>EN</b> Solid bricks or reinforced concrete wall <b>ES</b> Pared de ladrillos comunes o cemento armado	<b>TV</b> MAX 45 kg 99 lbs
VESA Max 600 mm X Max 400 mm Y		<b>IT</b> Cartongesso <b>FR</b> Plaques de plâtre <b>EN</b> Plasterboard <b>ES</b> Placas de yeso	<b>TV</b> MAX 40 kg 88 lbs

**1:1**

<b>T1 (x8)</b> Ø6 x 60 L4468169	<b>TV (x4)</b> Ø6 x 16 L7950244	Ø6 x 30 L7950139	Ø8 x 20 L7950137	Ø8 x 30 L7950203
<b>T2 (x8)</b> Ø8 L4468168	<b>TV (x4)</b> Ø8 x 15 L4459513	Ø6 x 15 L4459513		

**1**

**2**

**3**

<b>TV</b> MAX 45 kg 99 lbs	<b>IT</b> Muro in mattoni pieni o cemento armato <b>FR</b> Mur en briques pleines ou en béton armé <b>EN</b> Solid bricks or reinforced concrete wall <b>ES</b> Pared de ladrillos comunes o cemento armado	<b>4</b>
<b>TV</b> MAX 40 kg 88 lbs	<b>IT</b> Cartongesso <b>FR</b> Plaques de plâtre <b>EN</b> Plasterboard <b>ES</b> Placas de yeso	<b>8</b>

**4**

**5**

**6**

**7**

**8**

**IT** Lastra tipo R - EN520:2004 +A1 2009  
**FR** Plaque type R - Norme EN520:2004 +A1 2009  
**EN** Board type R - EN520:2004 +A1 2009  
**ES** Placa tipo R - Norme EN520:2004 +A1 2009

**9**

**9**

