

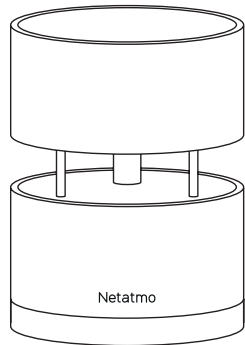

# Netatmo

## Smart Anemometer





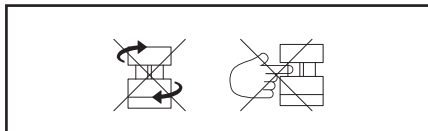
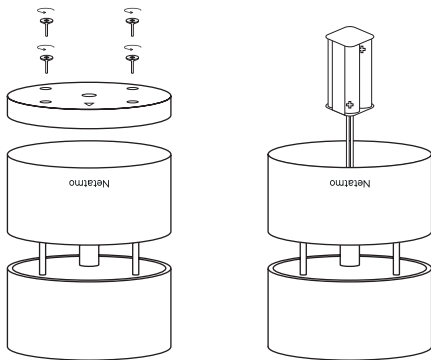



1



← →  
10 cm / 4 in

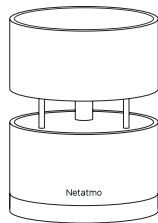



2



<http://add.netatmo.com>





3

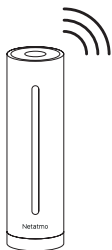



4

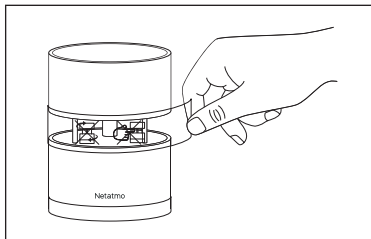
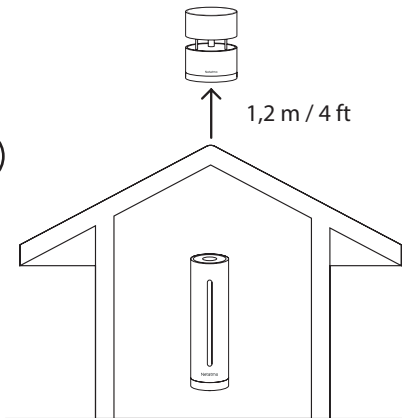

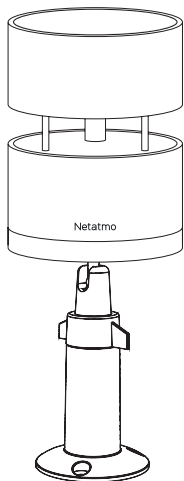

Sold separately / Vendu séparément / Wird separat verkauft / Se vende por separado / Venduto separatamente /  
Vendido separadamente / Apart verkocht / Säljes separat / 单独出售 / 單獨出售 / 別壳



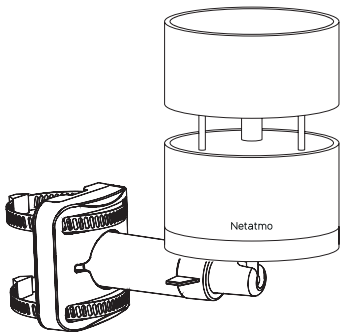

<http://netatmo.com/mount>





### Safety warnings

This device is not intended for use by persons (including children) with reduced physical, sensory or mental capabilities, or lack of experience and knowledge, unless they have been given supervision or instruction concerning use of the appliance by a person responsible for their safety. Children should be supervised to ensure that they do not play with the appliance.

Before inserting the batteries, check that the contacts in the device and on the batteries are clean, and clean them if necessary. Note the polarity (+/-) when inserting the batteries. Do not throw the batteries into a fire, short-circuit it or dismantle it. Keep children away from batteries. Seek medical attention immediately if a battery is swallowed.

### Consignes de sécurité

Cet appareil n'est pas destiné à être utilisé par des personnes (notamment des enfants) dont les capacités physiques, sensorielles ou mentales sont réduites, ou qui n'ont pas d'expérience et de connaissances, à moins qu'elles ne soient surveillées ou instruites concernant l'utilisation de l'appareil par une personne responsable de leur sécurité. Les enfants doivent être surveillés pour s'assurer qu'ils ne jouent pas avec l'appareil.

Avant d'insérer les piles, vérifiez que les contacts de l'appareil et des piles sont propres, et nettoyez-les si nécessaire. Respectez la polarité (+/-) lors de l'insertion des piles.

Ne pas jeter les piles dans un incendie, créer de court-circuit ou les démonter. Gardez les enfants loin des piles. Consulter immédiatement un médecin si une pile est avalée.

### Sicherheitshinweise

Dieses Gerät eignet sich nicht für die Nutzung von Personen (einschließlich Kindern) mit eingeschränkten physischen, sensorischen oder mentalen Fähigkeiten, unzureichender Erfahrung und ungenügenden Kenntnissen, es sei denn sie stehen unter Aufsicht oder haben die entsprechenden Anweisungen für die Nutzung des Geräts von einer Person bekommen, die für ihre Sicherheit verantwortlich ist. Kinder sollten unter Aufsicht stehen, damit Sie Gewissheit darüber haben, dass sie nicht mit dem Gerät spielen.

Vor dem Einsetzen der Batterien sollte geprüft werden, dass die Kontakte im

Gerät und auf den Batterien sauber sind. Gegebenenfalls müssen die Kontakte gereinigt werden. Bitte achten Sie beim Einsetzen der Batterien auf die Polarität (+/-). Die Batterien nicht ins Feuer werfen, nicht kurzschließen oder auseinanderbauen. Batterien dürfen nicht in die Hände von Kindern gelangen. Bei Verschlucken einer Batterie ist unmittelbar einen Arzt aufzusuchen.

### Advertencias de seguridad

Este dispositivo no está diseñado para que lo utilicen personas (incluidos niños) con facultades físicas, sensoriales o mentales reducidas ni con falta de experiencia y conocimiento, salvo que una persona responsable de su seguridad los supervise o instruya sobre el uso del aparato. Hay que asegurarse de que los niños no jueguen con el aparato.

Antes de ponerle las pilas, comprueba que los contactos del dispositivo y de las pilas estén limpios y límpialos si es necesario. Pon las pilas teniendo en cuenta la ubicación correcta de cada polo (+/-). No tires las pilas al fuego, no las cortocircuites ni las desmontes. Mantén a los niños alejados de las pilas. Acude inmediatamente al médico en caso de ingestión de una pila.

### Avvisi di sicurezza

Questo dispositivo non è destinato all'uso da parte di persone (compresi i bambini) con ridotte capacità fisiche, sensoriali o mentali, o sprovviste della necessaria esperienza e conoscenza, a meno che siano sorvegliate o abbiano ricevuto istruzioni sull'uso del dispositivo da parte di una persona responsabile della loro sicurezza. I bambini devono essere sorvegliati per assicurarsi che non giochino con l'apparecchio.

Prima di inserire le pile, controllare che i contatti nel dispositivo e sulle pile siano puliti e, se necessario, pulirli. Rispettare la polarità (+/-) quando si inseriscono le pile. Non gettare le pile nel fuoco, non cortocircuitarle né smontarle. Tenere i bambini lontani dalle pile. Consultare immediatamente un medico in caso di ingestione di una pila.

### Avisos de segurança

Este dispositivo não se destina à utilização por pessoas (incluindo crianças) com capacidades físicas, sensoriais ou mentais reduzidas, ou falta de experiência e conhecimento, a menos que tenham sido supervisionadas ou





instruções sobre o uso do aparelho por uma pessoa responsável pela sua segurança. As crianças devem ser supervisionadas para garantir que não brinquem com o aparelho.

Antes de inserir as baterias, verifique se os contatos no dispositivo estão limpos e limpe-os, se necessário. Observe a polaridade (+/-) ao inserir as baterias. Não coloque as baterias no fogo, não provoque um curto-circuito ou desmonte-as. Mantenha as crianças afastadas das baterias. Procure atendimento médico imediatamente se a bateria for engolida.

#### Veiligheidswaarschuwingen

Dit apparaat is niet bedoeld voor gebruik door personen (waaronder kinderen) met verminderde lichamelijke, zintuiglijke of geestelijke vermogens, of gebrek aan ervaring en kennis, tenzij zij onder toezicht staan of instructies over het gebruik van het apparaat hebben gekregen van een persoon die verantwoordelijk is voor hun veiligheid. Kinderen moeten onder toezicht staan om ervoor te zorgen dat zij niet met het apparaat spelen.

Voordat u de batterijen plaatst, dient u te controleren of de contacten in het apparaat en op de batterijen schoon zijn, en deze indien nodig schoon te maken. Let op de polariteit (+/-) als u de batterijen plaatst. Werp de batterijen niet in open vuur, voorkom kortsluiting en demonteer de batterijen niet. Hou kinderen uit de buurt van batterijen. Raadpleeg onmiddellijk een arts indien een batterij is ingeslikt.

#### Säkerhetsmeddelanden

Denna enhet är inte avsedd för att användas av personer (inklusive barn) med begränsad fysisk, sensorisk eller psykisk kapacitet eller personer som saknar erfarenhet och kunskap om enheten, så länge dessa inte har fått utbildning rörande enhetens handhavande av en person som ansvarar för säkerheten. Barn ska hållas under uppsikt så att de inte leker med enheten. Innan du sätter i batterierna, kontrollera att kontakterna i enheten och på batteriet är rena. Rengör dem vid behov. Observera polerna (+/-) när du sätter i batterierna. Batterierna får inte kastas i öppen eld, kortslutas eller plockas isär. Se till att barn inte kan komma åt batterierna. Om ett batteri skulle sväljas, sök omedelbart läkarvård.

#### EU Declaration of Conformity

**български [Bulgarian]** - С настоящото NETATMO декларира, че този тип радиосъоръжение NWA01 е в съответствие с Директива 2014/53/ЕС. Цялостният текст на ЕС декларацията за съответствие може да се намери на следния интернет адрес:

**Česky [Czech]** - Tímto NETATMO prohlašuje, že typ rádiového zařízení NWA01 je v souladu se směrnici 2014/53/EU. Úplné znění EU prohlášení o shodě je k dispozici na této internetové adrese:

**Dansk [Danish]** - Hermed erklærer NETATMO, at radioudstyrstypen NWA01 er i overensstemmelse med direktiv 2014/53/EU. EU-overensstemmelse-serklæringens fulde tekst kan findes på følgende internetadresse:

**Deutsch [German]** - Hiermit erklärt NETATMO, dass der Funkanlagentyp NWA01 der Richtlinie 2014/53/EU entspricht. Der vollständige Text der EU-Konformitätserklärung ist unter der folgenden Internetadresse verfügbar:

**Eesti [Estonian]** - Käesolevaga deklareerib NETATMO, et käesolev radioseadme tüüp NWA01 vastab direktiivi 2014/53/EL nõuetele. ELi vastavus-deklaratsiooni täielik tekst on kättesaadav järgmisel internetiaadressil:

**English** - Hereby, NETATMO, declares that the radio equipment type NWA01 is in compliance with Directive 2014/53/EU. The full text of the EU declaration of conformity is available at the following internet address:

**Español [Spanish]** - Por la presente, NETATMO declara que el tipo de equipo radioeléctrico NWA01 es conforme con la Directiva 2014/53/UE. El texto completo de la declaración UE de conformidad está disponible en la dirección Internet siguiente:

**Ελληνική [Greek]** - Με την παρούσα ο/η NETATMO, δηλώνει ότι ο ραδιοεξοπλισμός NWA01 πληροί την οδηγία 2014/53/ΕΕ. Το πλήρες κείμενο της δήλωσης συμμόρφωσης ΕΕ διατίθεται στην ακόλουθη ιστοσελίδα στο διαδίκτυο:

**Suomi [Finnish]** - NETATMO vakuuttaa, että radiolaitetyypin NWA01 on direktiivin 2014/53/EU mukainen. EU-vaatimustenmukaisuusvakuutuksen täysi-





mittainen teksti on saatavilla seuraavassa internetosoitteessa:

**Français [French]** - Le soussigné, NETATMO, déclare que l'équipement radioélectrique du type NWA01 est conforme à la directive 2014/53/UE. Le texte complet de la déclaration UE de conformité est disponible à l'adresse internet suivante:

**Hrvatski [Croatian]** - NETATMO ovime izjavljuje da je radijska oprema tipa NWA01 u skladu s Direktivom 2014/53/EU. Cjeloviti tekst EU izjave o sukladnosti dostupan je na sljedećoj internetskoj adresi:

**Magyar [Hungarian]** - NETATMO igazolja, hogy a NWA01 típusú rádióberendezés megfelel a 2014/53/EU irányelvnek. Az EU-megfelelőségi nyilatkozat teljes szövege elérhető a következő internetes címen:

**Italiano [Italian]** - Il fabbricante, NETATMO, dichiara che il tipo di apparecchiatura radio NWA01 è conforme alla direttiva 2014/53/UE. Il testo completo della dichiarazione di conformità UE è disponibile al seguente indirizzo Internet:

**Latviski [Latvian]** - Ar šo NETATMO deklarē, ka radioiekārta NWA01 atbilst Direktīvai 2014/53/ES. Pilns ES atbilstības deklarācijas teksts ir pieejams šādā interneta vietnē:

**Lietuvių [Lithuanian]** - Aš, NETATMO, patvirtinu, kad radijo įrenginių tipas NWA01 atitinka Direktyvą 2014/53/ES. Visas ES atitikties deklaracijos tekstas prieinamas šiuo interneto adresu:

**Malti [Maltese]** - B'dan, NETATMO, niddikjara li dan it-tip ta' taghmir tar-radju NWA01 huwa konformi mad-Direttiva 2014/53/UE. It-test kollu tad-dikjarazzjoni ta' konformità tal-UE huwa disponibbli f'dan l-indirizz tal-Internet li ġej:

**Nederlands [Dutch]** - Hierbij verklaar ik, NETATMO, dat het type radioapparatuur NWA01 conform is met Richtlijn 2014/53/EU. De volledige tekst van de EU-conformiteitsverklaring kan worden geraadpleegd op het volgende internetadres:

**Norsk [Norwegian]** - Netatmo erklærer herved at radioutstyrstypen NWA01 er i samsvar med direktiv 2014/53/EU. Den fullstendige EU-samsvarserklæringen er tilgjengelig på følgende nettadresse:

**Polski [Polish]** - NETATMO niniejszym oświadcza, że typ urządzenia radiowego NWA01 jest zgodny z dyrektywą 2014/53/UE. Pełny tekst deklaracji zgodności UE jest dostępny pod następującym adresem internetowym:

**Português [Portuguese]** - O abaixo assinado NETATMO declara que o presente tipo de equipamento de rádio NWA01 está em conformidade com a Diretiva 2014/53/UE. O texto integral da declaração de conformidade está disponível no seguinte endereço de Internet:

**Română [Romanian]** - NETATMO declară, prin prezenta, că tipul de echipament radio NWA01 este în conformitate cu Directiva 2014/53/UE. Textul complet al declarației de conformitate a UE este disponibil pe internet la următoarea adresă:

**Slovensky [Slovak]** - NETATMO týmto vyhlasuje, že rádiové zariadenie typu NWA01 je v súlade so smernicou 2014/53/EÚ. Úplné EÚ vyhlásenie o zhode je k dispozícii na tejto internetovej adrese:

**Slovensko [Slovenian]** - NETATMO potrjuje, da je tip radijske opreme NWA01 skladen z Direktivo 2014/53/EU. Celotno besedilo izjave EU o skladnosti je na voljo na naslednjem spletnem naslovu:

**Svenska [Swedish]** - Härmed försäkras NETATMO att denna typ av radioutrustning NWA01 överensstämmer med direktiv 2014/53/EU. Den fullständiga texten till EU-försäkran om överensstämmelse finns på följande webbadress:

**Türkçe [Turkish]** - İşbu vesile ile NETATMO; radyo ekipman tipinin NWNWA01, 2014/53/AB Yönetmeliği ile uyumlu olduğunu beyan eder. AB uygunluk beyanının tam metni, aşağıdaki Internet adresinde mevcuttur:

<http://www.netatmo.com/declaration/nwa>





#### FCC Statement

This equipment has been tested and found to comply with the limits for a Class B digital device, pursuant to part 15 of the FCC rules. These limits are designed to provide reasonable protection against harmful interference in a residential installation.

This equipment generates, uses and can radiate radio frequency energy and, if not installed and used in accordance with the instructions, may cause harmful interference to radio communications. However, there is no guarantee that interference will not occur in a particular installation.

If this equipment does cause harmful interference to radio or television reception, which can be determined by turning the equipment off and on, the user is encouraged to try to correct the interference by one or more of the following measures:

- Reorient or relocate the receiving antenna.
- Increase the separation between the equipment and receiver.
- Connect the equipment into an outlet on a circuit different from that to which the receiver is connected.
- Consult the dealer or an experienced radio/TV technician for help. Should you need further certification information (FCC ID, IC) please unscrew the cover at the bottom of the product.

#### FCC Radiation Exposure Statement

This device complies with FCC RF radiation exposure limits set forth for general population (uncontrolled exposure). This device must be installed to provide a separation distance of at least 20cm from all persons and must not be collocated or operating in conjunction with any other antenna or transmitter. This device NWA01 complies with Part 15 of the FCC Rules. Operation is subject to the following two conditions: (1) This device may not cause harmful interference, and (2) this device must accept any interference received, including interference that may cause undesired operation.

#### Caution!

This equipment may not be modified, altered, or changed in any way without signed written permission from NETATMO. Unauthorized modification may

void the equipment authorization from the FCC and will void the NETATMO warranty.

#### Canadian Compliance Statement

This device complies with Industry Canada licence-exempt RSS standard(s). Operation is subject to the following two conditions: (1) this device may not cause interference, and (2) this device must accept any interference, including interference that may cause undesired operation of the device.

Under Industry Canada regulations, this radio transmitter may only operate using an antenna of a type and maximum (or lesser) gain approved for the transmitter by Industry Canada.

To reduce potential radio interference to other users, the antenna type and its gain should be so chosen that the equivalent isotropically radiated power (e.i.r.p.) is not more than that necessary for successful communication.

This device complies with Industry Canada RF radiation exposure limits set forth for general population (uncontrolled exposure). This device must be installed to provide a separation distance of at least 20cm from all persons and must not be collocated or operating in conjunction with any other antenna or transmitter.

*Le présent appareil est conforme aux CNR d'Industrie Canada applicables aux appareils radio exempts de licence. L'exploitation est autorisée aux deux conditions suivantes: (1) il ne doit pas produire de brouillage, et (2) l'utilisateur du dispositif doit être prêt à accepter tout brouillage radioélectrique reçu, même si ce brouillage est susceptible de compromettre le fonctionnement du dispositif.*

*Conformément à la réglementation d'Industrie Canada, le présent émetteur radio peut fonctionner avec une antenne d'un type et d'un gain maximal (ou inférieur) approuvé pour l'émetteur par Industrie Canada.*

*Dans le but de réduire les risques de brouillage radioélectrique à l'intention d'autres utilisateurs, il faut choisir le type d'antenne et son gain de sorte que la puissance isotrope rayonnée équivalente (p.i.r.e.) ne dépasse pas l'intensité*





*nécessaire à l'établissement d'une communication satisfaisante.  
Le présent appareil est conforme aux niveaux limites d'exigences  
d'exposition RF aux personnes définies par Industrie Canada. Cet  
appareil doit être installé afin d'offrir une distance de séparation d'au  
moins 20cm avec l'utilisateur, et ne doit pas être installé à proximité ou  
être utilisé en conjonction avec une autre antenne ou un autre émetteur.*

#### **Taiwan Wireless Statements**

##### 無線設備的警告聲明

本產品符合低功率電波輻射性電機管理辦法 第十二條、十四條等條文規定:

- 1.經型式認證合格之低功率射頻電機，非經許可，公司、商號 或使用者均不得擅自變更頻率、加大功率或變更原設計之特性及功能。
- 2.低功率射頻電機之使用不得影響飛航安全及干擾合法通信；經發現有干 擾現象時，應立即停用，並改善至無干擾時方得繼續使用。 前項合法通信，指依電信法規定作業之無線電通信。 低功率射頻電機須忍受合法通信或工業、科學及醫療用電波輻射性電機設 備之干擾。

#### **Limited warranty for purchases within Australia**

Our goods come with guarantees that cannot be excluded under the Australian Consumer Law. You are entitled to a replacement or refund for a major failure and compensation for any other reasonably foreseeable loss or damage. You are also entitled to have the goods repaired or replaced if the goods fail to be of acceptable quality and the failure does not amount to a major failure. The company giving the warranty (the warrantor) is Netatmo Limited., 18/F Wanchai Central Bldg., 89 Lockhart Rd, Wanchai, Hong Kong, contact-support@netatmo.com or contact your local reseller for assistance. The warranty applies for a period of 12 months from purchase from an authorised Netatmo reseller. Any faults or defects arisen from misuse or normal wear and tear are not covered by warranty. Any modifications to products will void the warranty. Items not covered by warranty are components that are expected to be replaced regularly, including without limitation: batteries and bracelets. The warrantor has the right to request the return of the product at your expense. The warranty does not cover any consequential loss or damage.





CE marking is the manufacturer's declaration that the product meets the requirements of the applicable EC directives.



WEEE symbol designates safe and responsible collection, recycling and recovery procedures for all types of electronic waste.



Universal recycling symbol.



The product complies with the Technical Regulations Conformity Certification of Specified Radio Equipment.



The product complies with the requirements of the relevant ACMA Standards.

FCC ID: The product complies with the limits for a Class B digital device, pursuant to part 15 of the FCC rules (USA).

IC: The product complies with Industry Canada license-exempt RSS standard(s).

Copyright Netatmo © 2020. All rights reserved.  
Reproduction and distribution prohibited without  
written authorization from Netatmo.



Product Model: NWA01 / FCC ID: N3A-NWA01 / IC: 10860A-NWA01





 <http://support.netatmo.com>



QSG-NWA

